

Robotic Mining Capstone (RMC)

Sidney Causey, Shayla Peak, Mohammed Aljameeli, Junot Damen,
Izaya Farrar, Eric Moseley, Michael Muller, Liam Sapper,
Chelsea Sweeney, Shelsy Toppenberg, Noah Walters



Faculty Advisor: Dr. Chiradeep Sen, Dept. of Mechanical Engineering, Florida Institute of Technology

MISSION

- Design a robot capable of traversing lunar terrain and building a regolith berm.
- Berm construction is essential to protect astronauts and critical lunar structures from radiation and the harsh space environment.
- RMC's robot is engineered to maximize berm volume and employ an efficient regolith storage mechanism.

EXCAVATION

- Composed of eight 3D-printed PLA bucket drums.
- Each drum holds an 80% fill capacity of 0.64 liters of fly ash.
- The drum capacity was predicted using Becker 3D[®] simulations and verified through physical testing.

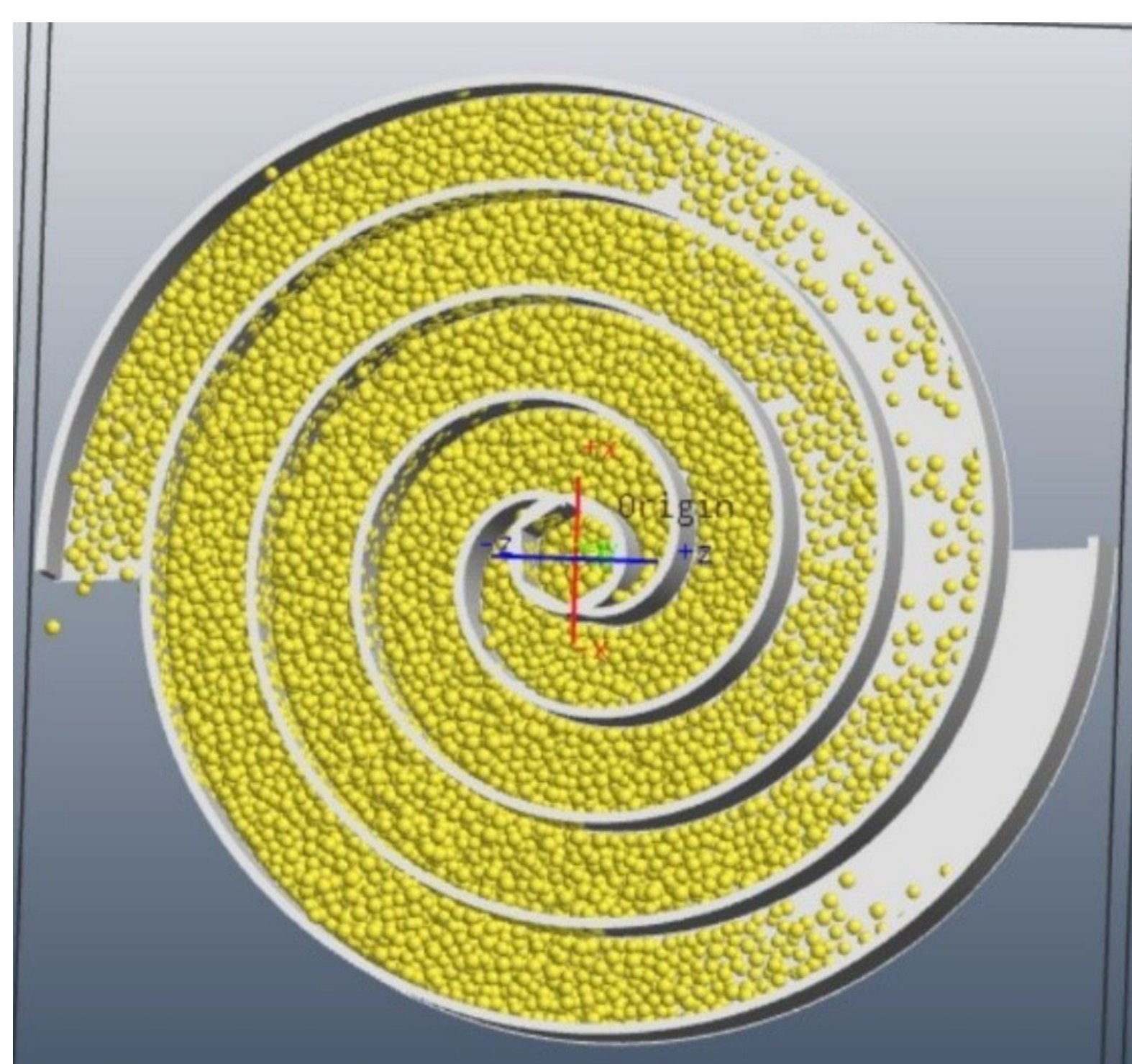

STRUCTURES

- The Ansys[®] model illustrates the FoS for the wheel, the blue areas denote complete safety while red areas indicate potential failure zones.

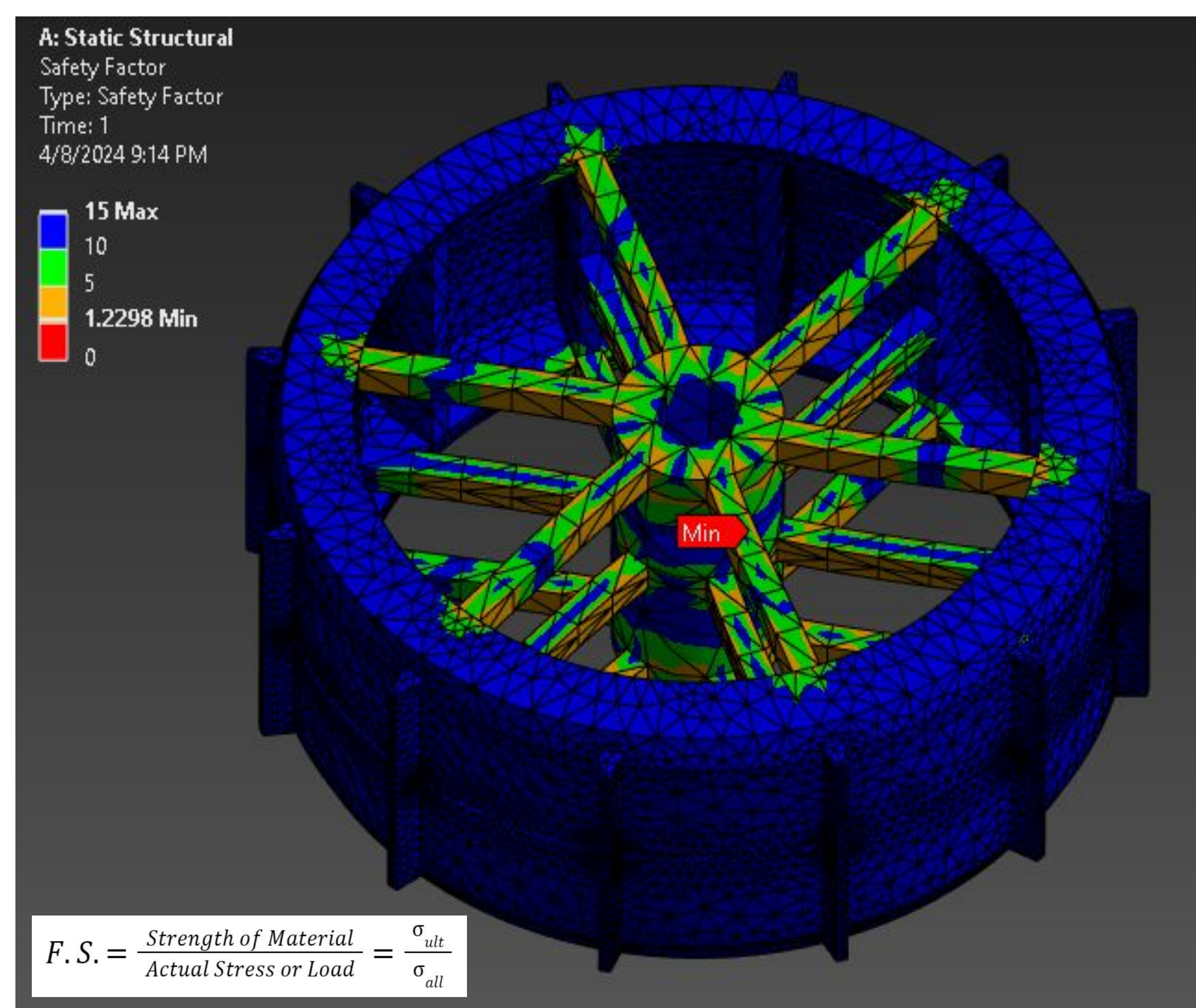

- The minimum FoS recorded is 1.2298.
- The chassis bending stress was predicted using a MATLAB[®] shear-moment script.

Lunar Robot Model

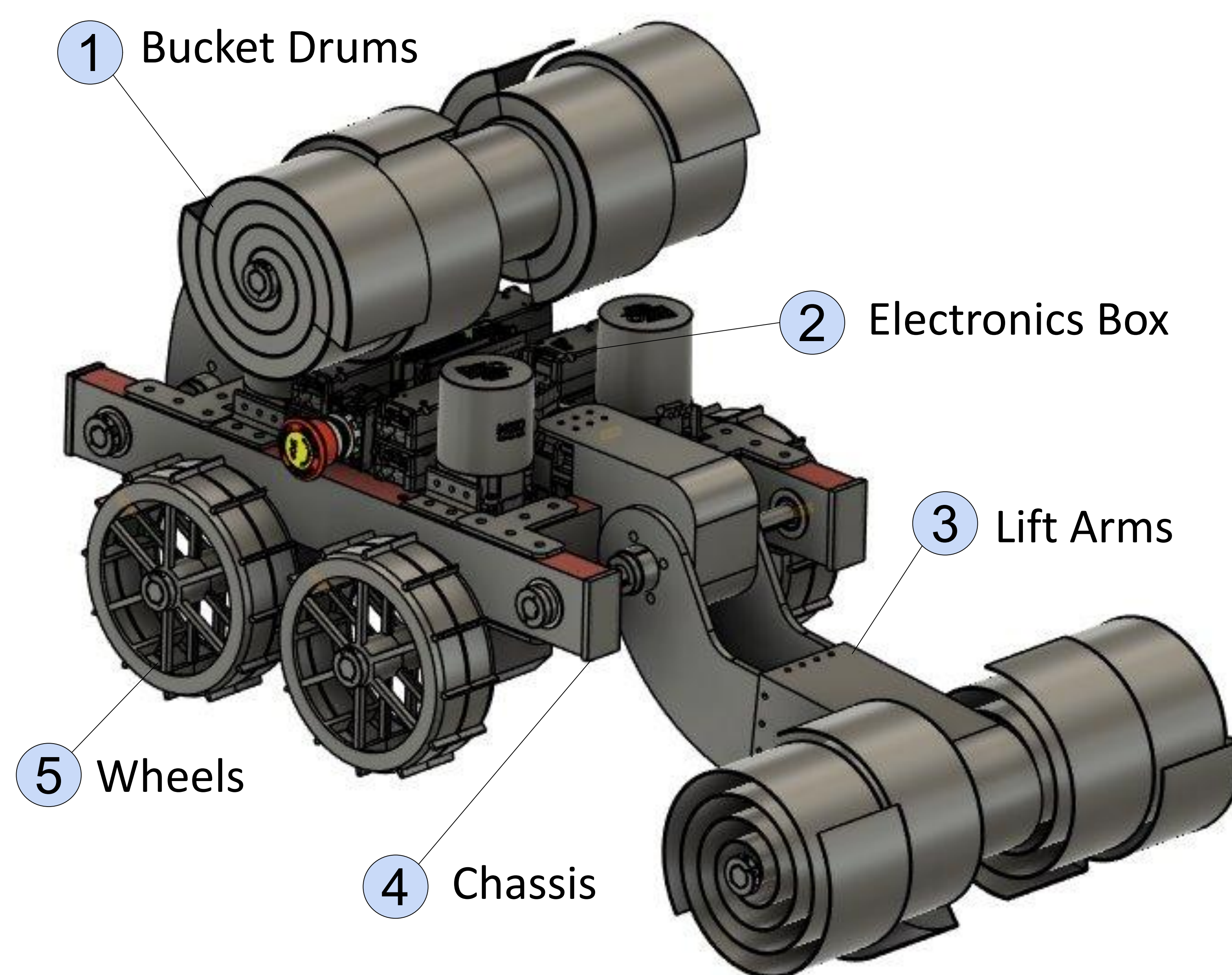

Materials: PLA, Al 6061, Al 6063, and Steel

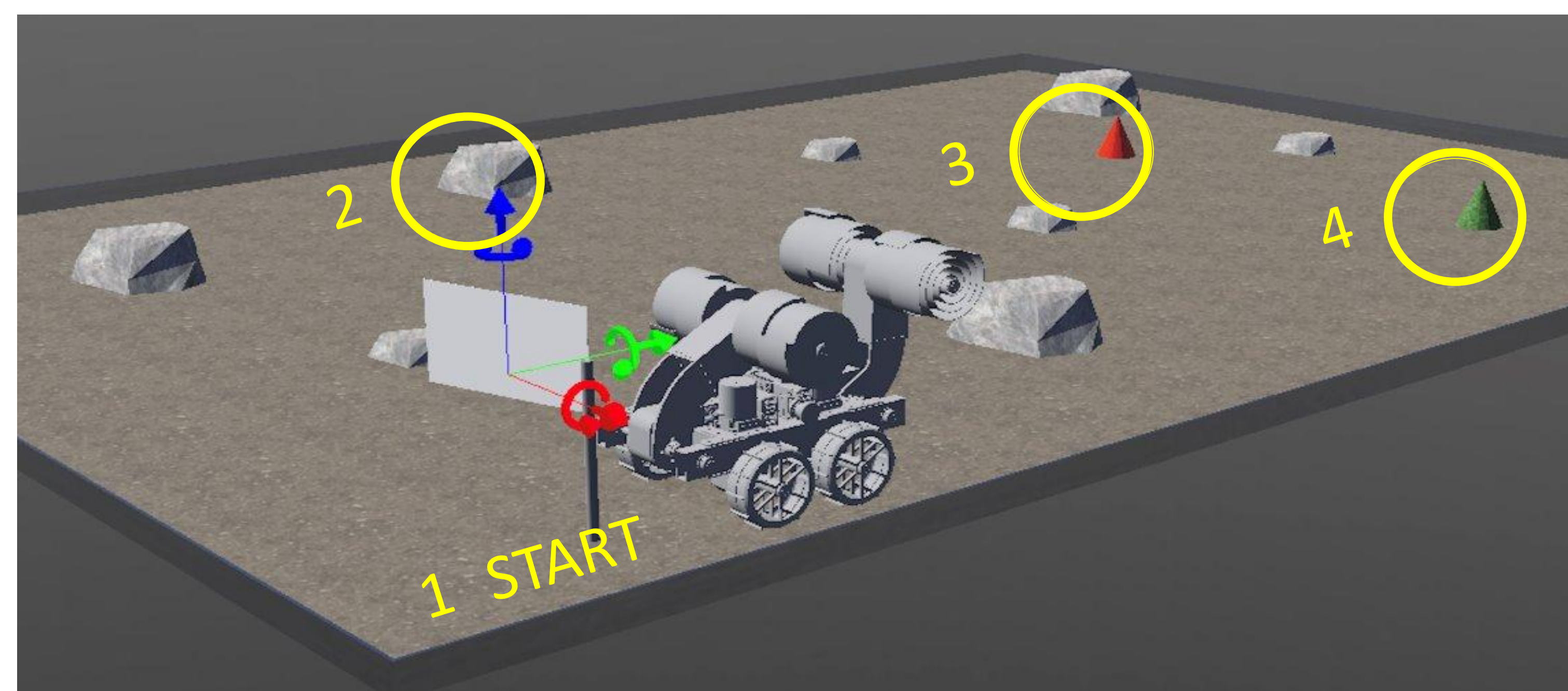

- Step 1:** The robot will begin at the starting zone.
- Step 2:** It will drive through the arena avoiding obstacles.
- Step 3:** It will reach the mining zone (red cone) and collect regolith.
- Step 4:** Once full, it will locate the construction zone (green cone) and build the berm.

CONTROLS

Electrical: Electronics Box

- | | |
|-----------------------|----------------------|
| 1. Emergency shut off | 5. Power distributor |
| 2. Hoist hook | 6. Battery 12V 9Ah |
| 3. Raspberry Pi HAT | 7. IMU |
| 4. Motor controller | |

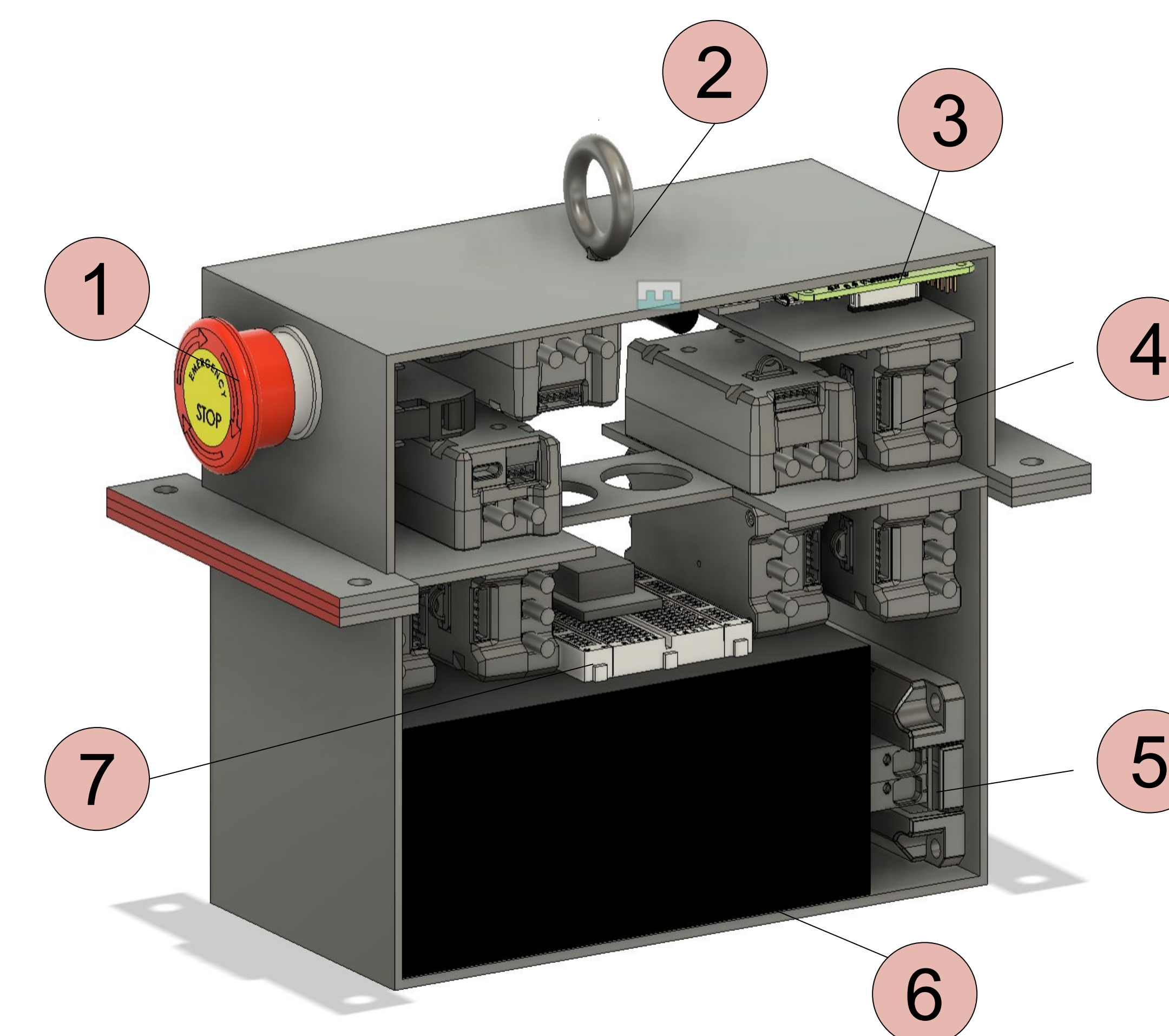

Software:

- Webots[®]:** Simulates mission arena with mock robot to refine the capabilities of the physical prototype.
- Python:** Navigation is performed using stored waypoints which appear on the GUI atop a cartesian position grid.
- Becker 3D[®]:** Simulates regolith particle loading and unloading from bucket drums.

RESULTS & FUTURE WORK

- Results:** Successful manual control for driving and excavating. The robot can build a 0.02 m³ berm in 4 trips.
- Future:** Refine the robot's autonomous operations script and image processing algorithms.